

Nonroad Equipment Operations Webinar

Presented by South Shore Clean Cities, Chicago Area Clean Cities,
Greater Lansing Area Clean Cities & Wisconsin Clean Cities



Nonroad Equipment Operations Webinar

April 7, 2021
1 p.m.-2p.m. CDT

*Lake Michigan
Consortium
Webinar Series*



Moderator



South Shore Clean Cities

Ryan Lisek

Project Manager

219-644-3690

rlisek@southshorecleancities.org

Speaker Lineup



HicksGas, LLC/DCC Propane
Bryan Summers
Regional Manager



Ariens Gravely
Mark Linkletter
Business Development
Manager

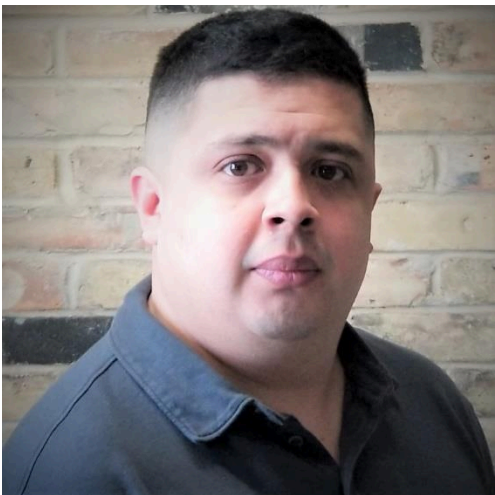

**Forest Preserves of
Cook County**
Jorge Campos
Equipment Supervisor



Ariens Gravely
Grant Wilson
Director of Product
Management

Clean Cities Partnerships



Partnerships & Grant Acquisitions



Contact Us!



Chicago Area Clean Cities

Samantha Bingham
Coordinator/CDOT Program Director

312-744-8096

info@chicagocleancities.org

*Interim point of contact is
John Walton, Chair of CACC
john@chicagocleancities.org



Greater Lansing Area Clean Cities

Maggie Striz Calnin
Coordinator

313-241-6211

Maggie@michigancleancities.org



South Shore Clean Cities

Carl Lisek
Executive Director

219-644-3690

clisek@southshorecleancities.org



Wisconsin Clean Cities

Lorrie Lisek
Executive Director

414-221-4958

Lorrie.Lisek@wicleancities.org

Non Road Equipment Operations – Propane powered landscaping equipment

April 2021



Benefits of Propane

Reduced emissions

Reduced labor expense

Reduced fuel loss

Stable fuel costs

Flexible infrastructure

Reduced Emissions

Studies show that compared to a gasoline mower, propane reduces greenhouse gas emissions by 16%, sulfur oxide emissions by 17% and nitrogen oxide emissions by 19%. Propane mowers also significantly reduce other polluting emissions such as ozone and particulate matter.

These emissions benefits help landscape contractors differentiate their businesses and appeal to green minded customers and businesses that have sustainability goals.

Propane mowers can also operate in most areas during ozone action days or air quality nonattainment days.

Reduced Labor Expense

Propane refueling infrastructure is set up on site. This saves time on having to visit off site fueling stations. Multiple crew members at off site fueling stations results in added employee cost.

Some propane mowers allow for multiple tank set ups per machine allowing a crew to cover a greater mowing area.

Replacement cylinders are mobile and can be changed on site with ease creating increased productivity.

Reduced Fuel Loss

Refueling landscape equipment results in 17 million gallons of spilled gasoline in the U.S. each year. These spills can kill grass and cause environmental hazards. Propane is a contained fuel source.

Propane equipment has a closed loop fuel system and an on-premise refueling infrastructure greatly lessening the opportunity and financial impact of fuel theft.

Stable Fuel Costs

Volatile gasoline pricing does not allow for good expense management.

Landscape equipment fuel demand is based primarily in the summer during propane's low demand season allows for better pricing.

Propane suppliers can also offer fixed pricing allowing for better budgeting for landscape companies.

Flexible Infrastructure

Propane's portability and multiple storage options allow flexibility in customer storage. Companies can start with smaller fuel storage amounts and increase as they add equipment.

Landscape companies can also convert and add propane powered equipment as needed. An entire fleet does not need to be converted at one time.

Equipment can be added as other pieces of equipment are retired.

Gravelly ProTurn-EV

Mark Linkletter
&
Grant Wilson



7 Apr 21

ARIENS CORE VALUES

WE WILL...

BE HONEST

BE FAIR

KEEP OUR
COMMITMENTS

RESPECT THE
INDIVIDUAL

ENCOURAGE
INTELLECTUAL
CURIOSITY

ARIENS CO VISION STATEMENT

PASSIONATE PEOPLE

ASTOUNDED CUSTOMERS

1933

ARIENS COMPANY
was founded in
Henry's Garage

FIRST PRODUCT
Rotary Tiller

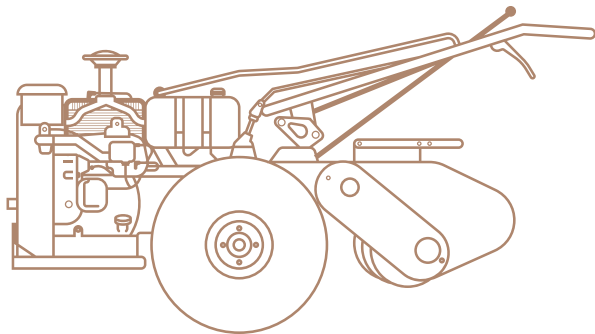

ARIENS | **CO**
EST. 1933



GENERATIONS OF ARIENS FAMILY HISTORY



HENRY ARIENS
Founder
President 1933-1956

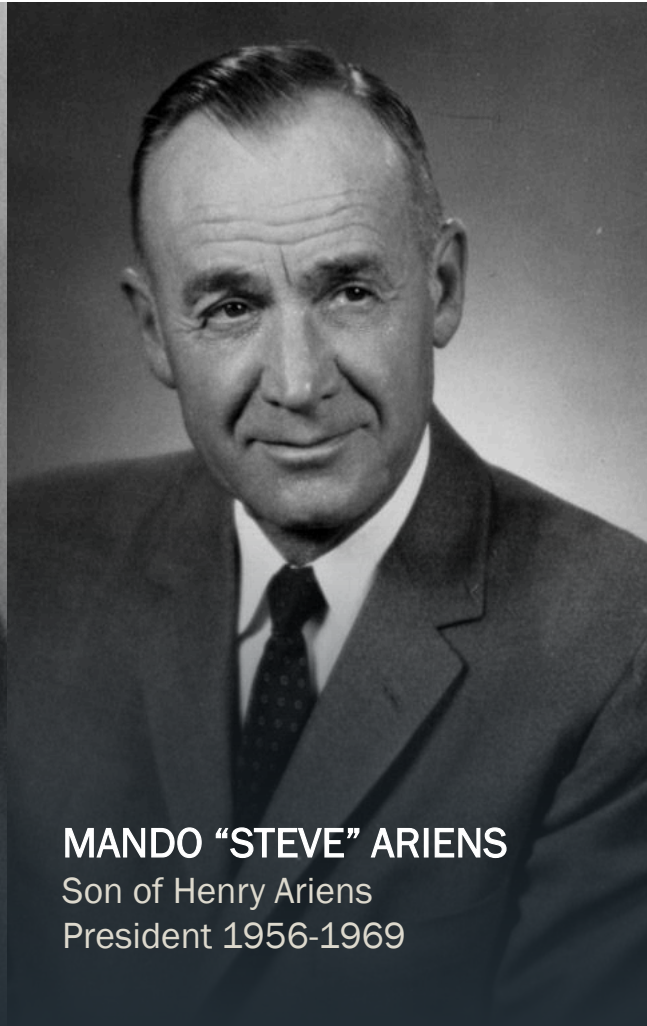

MANDO "STEVE" ARIENS
Son of Henry Ariens
President 1956-1969



MICHAEL ARIENS
Grandson of Henry Ariens
President 1969-1992



DAN ARIENS
Great-Grandson of Henry Ariens
Chairman & CEO 1998-Present

ENTERPRISE

ARIENS | **CO**
EST. 1933

SERVICE

ARIENS | **ACADEMY**

ARIENS | **FOUNDATION**

ARIENS | **HOSPITALITY**

RAPID | **CARE**

PRODUCT



ARIENS



GRAVELLY

COUNTAX



Westwood

ARIENS | **CO**
EST. 1933

MANUFACTURING FACILITIES



Plant 1 – Lawn/HQ
340,000 SqFt



Plant 3 – Snow
250,000 SqFt



Plant 4 – RapidCare
140,000 SqFt

MANUFACTURING FOOTPRINT

Brillion Plant 1:	340,000
Brillion Plant 3:	250,000
Brillion Plant 4:	140,000
Countax, U.K.	150,000
TOTAL:	880,000 SqFt

TEST & VALIDATION

Product Verification Center Brillion, WI

13,000 Sq Ft Facility

Hot Cell

Durability Lab

ANSI Lab

4-Post Shaker Table

Dedicated Field Test Facility Sebring, Florida

680+ acres

24x7 testing capability



Conservation Timeline

2008

Mike Ariens Trail



2015

Bee Hives & Honey Sales Introduced



WILDLIFE
HABITAT
COUNCILSM

2020

First WHC Certification for Prairie/Oak Savanna



2020

Dedicated 100 More Acres to Conservation & Trailhead



2014

Prairie Seeding and Oak/Hickory Tree Planting

2017

Joined Wildlife Habitat Council

2020

Stone Prairie Established

WHC Conservation Certification

The standard for corporate conservation actions – producing quantitative benefits for corporations, communities and the environment.

[Log in or register now.](#)



WILDLIFE
HABITAT
COUNCIL®

649 CERTIFIED PROGRAMS
25 COUNTRIES



WILDLIFE
HABITAT
COUNCIL®

Every act of conservation matters.



WHC CONSULTING



CERTIFICATION



IMPACT



WHC CERTIFICATION 2020 **Prairie Oak Savanna**

- Open-grown oaks surrounded by prairie grasses and flowering plants
- Once common in Wisconsin:
5.5 million acres
- Estimated that only 0.01 percent remains

One of the rarest habitat types in the world

Why EV? Why Now?

- Environmental Concerns
 - Fossil Fuels, emissions
- Noise Concerns
 - Bystander - Schools, Care Facilities, Housing Complexes
 - Operator
- Ariens/Gravely made a strategic decision to invest on the front end of the Gas to Electric transition in the Commercial Marketplace.



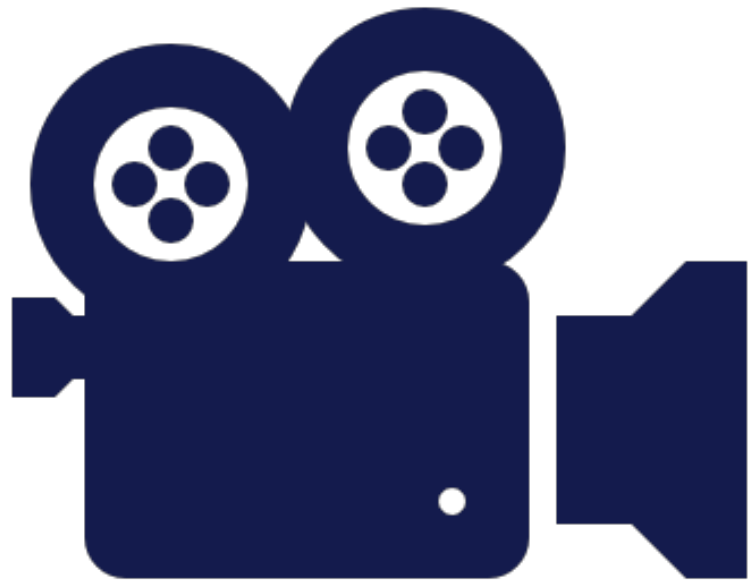

Video: Pro-Turn EV

Gravely PT- EV Complete System Solution

•The Gravely brand has over 100 years of experience in designing and developing outdoor power equipment to meet the tough demands of commercial landscape contractors.

Gravely PT-EV has the following proprietary components

FusionCore
Batteries

Wheel Drive
Motors

Spindle Motors

Gravely either developed these components or partnered with vendors to have these designed and built to our specifications

FusionCore Batteries

- Exclusive to AriensCo
- Power of 4-5 hrs of Continuous Cutting Time
- Light & Replaceable Quick Swap System
- Regulated by Battery Management System
- Durable

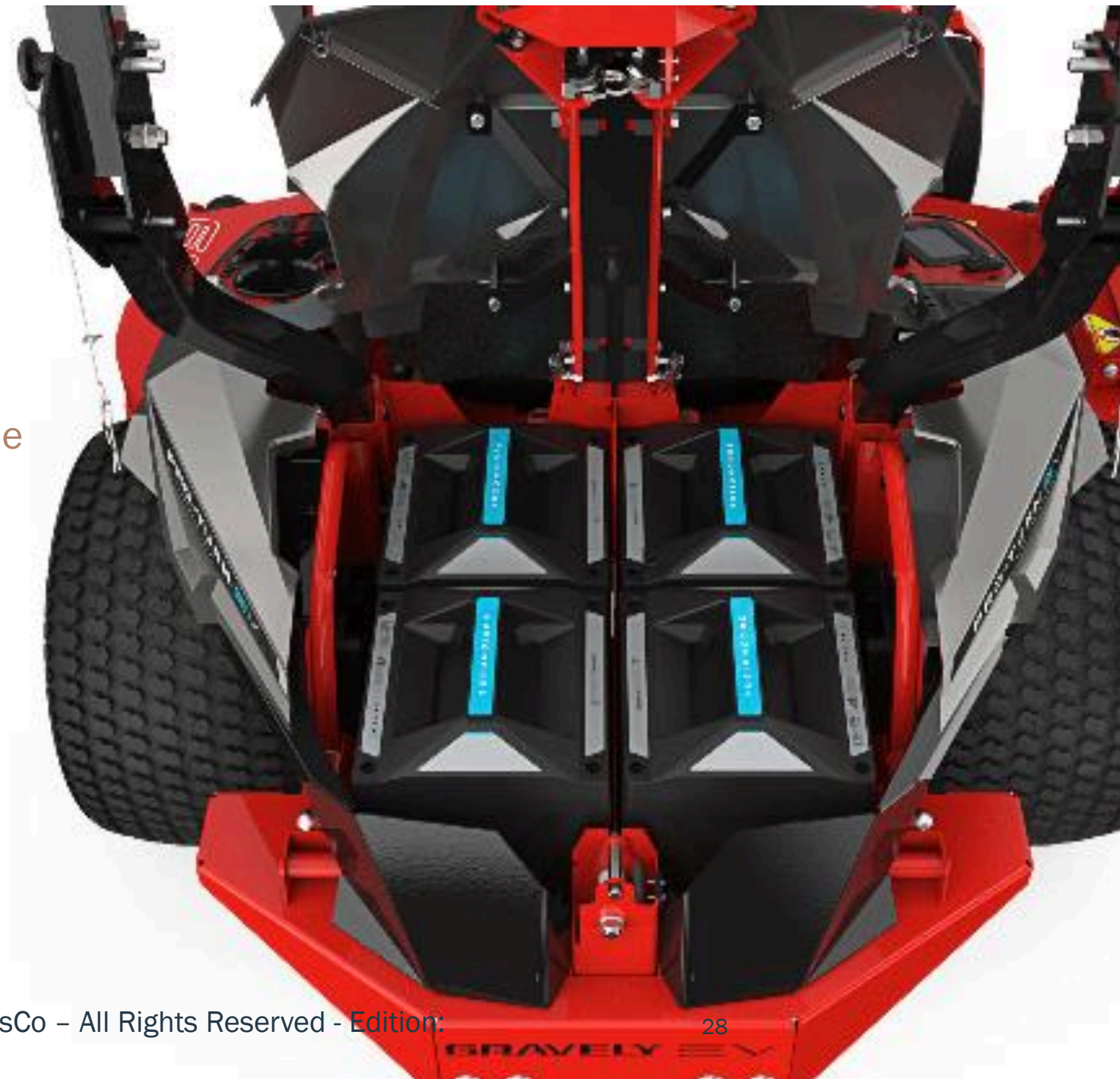

Wheel Drive Motor Summary

- Exclusive Proprietary Design
- No Hydraulic Oil / Belt Changes
- Wheel Drive Motors Almost Double Size of Competitors
- Consistent Power Delivery
- Smooth Responsive Control



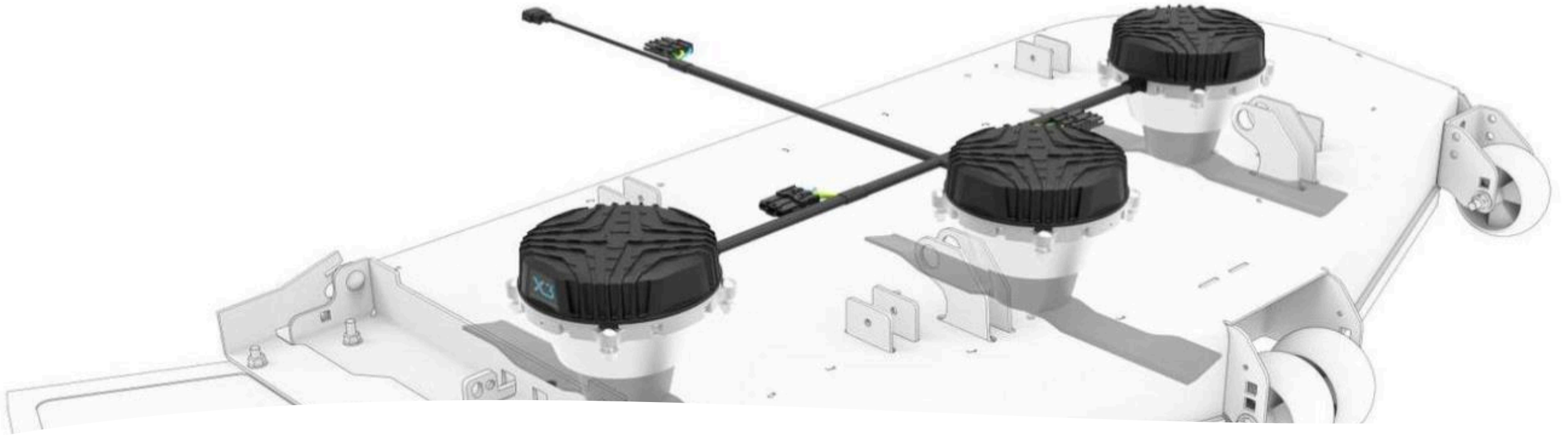

Spindle Motor Summary

- Exclusive Design
- No belts
- Consistent Power Delivery
- Protective Blade Slip Feature

Barriers to Conversion

- “Range Anxiety”
 - “I can’t dump a can of gas in an electric mower when it run out of energy”
 - “If it runs out of charge the asset is useless for 12 hours”
 - “What if I can’t get through my day before it dies”
 - What if you could “dump a can of gas in it”
- Cost
 - What is the ROI?
- Performance
 - Will it meet our (Gravely) standard of a “Commercial Mower”?
- Technology – It’s new, is it reliable?



ARIENS | CO

EST. 1933

Contact for Questions
Mark Linkletter
Commercial Business Development Manager
815-900-8942
minkletter@ariensco.com

[Full Length Video of the Gravely PT-EV](#)



Propane mowers purchased:

- 16 Gravely Pro-Turn 472, 72" Propane riding mowers in 2012
- 16 Gravely Pro-Turn 472, 72" Propane riding mowers in 2014
- 9 Gravely Pro-Turn 472, 72" Propane riding mowers in 2017

Key Successes:

- Applied for and were awarded grants through the Propane Education & Research Council and the Illinois Propane Gas Association
- Utilized cooperative contracts to save on time and purchase savings
- All purchases have been done through the same manufacturer and delivering dealer
- Ongoing communication with both the manufacturer and dealer

Future Plans:

- Electric mowers
- Electric power equipment



Type your questions in the chat box!



Connect with our speakers!



HicksGas, LLC/DCC Propane

Bryan Summers

Regional Manager

312-882-0513

Bryan.summers@dccpropane.com



Ariens Gravelly

Mark Linkletter

Business Development Manager

815-900-8942

minkletter@ariensco.com

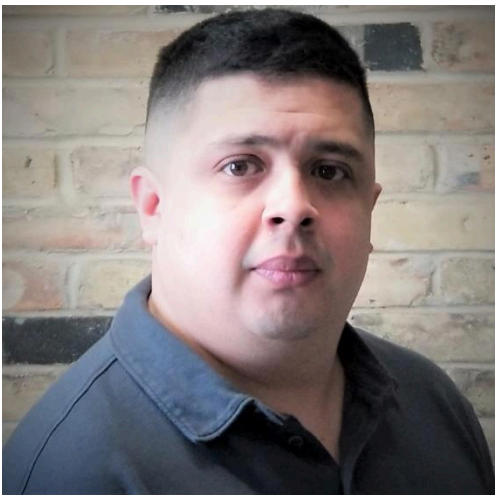

**Forest Preserves of
Cook County**

Jorge Campos

Equipment Supervisor

708-771-1552

Jorge.campos@cookcountyil.gov



Ariens Gravelly

Grant Wilson

Director of Product Management

920-716-1802

gwilson@ariensco.com

Connect with our partners!



Chicago Area Clean Cities

Samantha Bingham
Coordinator/CDOT Program Director
312-744-8096
info@chicagocleancities.org

*Interim point of contact is
John Walton, Chair of CACC
john@chicagocleancities.org



Greater Lansing Area Clean Cities

Maggie Striz Calnin
Coordinator
313-241-6211
Maggie@michigancleancities.org



South Shore Clean Cities

Carl Lisek
Executive Director
219-644-3690
clisek@southshorecleancities.org



Wisconsin Clean Cities

Lorrie Lisek
Executive Director
414-221-4958
Lorrie.Lisek@wicleancities.org

Coming Up...



smart

INNOVATIVE WISCONSIN EV SOLUTIONS WEBINAR

THURSDAY, APRIL 8, 2021 10 A.M. - 11 A.M. CENTRAL

electric drive

PRESENTED BY

 **ENTECH**™ SOLUTIONS **FAITH** TECHNOLOGIES  Wisconsin Biogas Council

A white lightning bolt graphic is positioned on the right side of the banner.

Innovative Wisconsin EV Solutions Webinar
April 8, 2021, 10 a.m. – 11 a.m. CDT
[Register Today!](#)



CNG

THINK GREEN, SAVE GREEN

WEBINAR: POWERING VEHICLES WITH COMPRESSED NATURAL GAS

Thursday, April 8 • 11AM



The banner features a background of various vehicle silhouettes in shades of gray.

Powering Vehicles with Compressed Natural Gas Webinar
April 8, 2021, 11 a.m. – 12 p.m. CDT
[Register Today!](#)

Coming Up...



IDEM VW Grant Options for School Bus Fleets Webinar
April 13, 2021, 1 p.m. – 2 p.m. CDT
[Register Today!](#)



IDEM VW Onroad & Nonroad Grant Options Webinar
April 15, 2021, 1 p.m. – 2 p.m. CDT
[Register Today!](#)

Thank you for attending!



Chicago Area Clean Cities Events Page: <https://chicagocleancities.org/events/>
Greater Lansing Area Clean Cities Events Page: <http://michigancleancities.org/events/>
South Shore Clean Cities Events Page: <https://southshorecleancities.org/event/>
Wisconsin Clean Cities Events Page: <https://wicleancities.org/events/>